

Our Mission

Our mission for this project is to build a monument incorporating salvaged steel from the World Trade Center here at S-GI that honors all of those who were involved in the events surrounding September 11th 2001. Furthermore, the monument will capture the historical essence of the events and help preserve the memory and legacy of those people. Most importantly, it will also serve as an invaluable lesson in compassion for our students to remember for years to come.

For more information, check out the project webpage at:



<http://www.springvillegi.org/webpages/911monument/>

A View of the Plan



Above is a view of the sculpture as it has been planned for the courtyard.

911 Memorial Sculpture

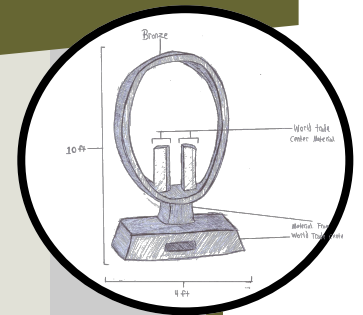

This project is being presented to you by:
Mr. Rob Valenti, HS Social Studies
Mr. Tim Baumgartner, HS Technology
Mr. Charles Houseman, HS Art
Ms. Angela Ginnitti, HS Art

From the beginning...

In 2006 S-GI Architecture classes proposed a courtyard in the front of the school after the Library/Science wing expansion was completed. Board approval was granted, and over the next three years, the first two phases were completed. The court-

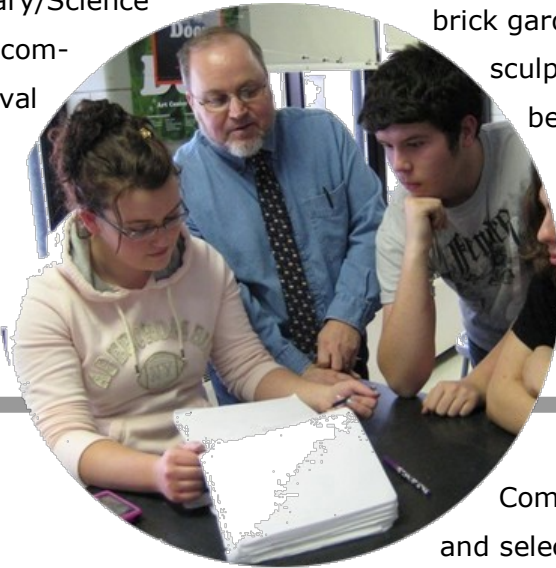

yard is now a gathering space and site for biology and landscaping class work, and includes an outdoor classroom space and memorial sculpture. Future plans include a brick garden wall, and additional sculptures. An access ramp will be installed this summer.

Shaping the Idea...

During the 2009-10 school year, a unique opportunity

arose for the school to be the site of a major sculpture installation. The Families of the 9/11 organization in New York made artifacts from the World Trade Center available to non-profit groups. Faculty member Mr. Rob Valenti became aware of this initiative and felt that our school and community should take advantage of this offer. Thus, the 911 Memorial Sculpture Project began to take form.

Planning the project...

It was at this point that a collaboration was formed between Mr. Valenti, Principal Vince Vanderlip, Tech teacher Tim Baumgartner, and Art teachers Angela Ginnitti and Charles Houseman to develop a design for a proposed sculpture integrating the steel from the WTC. Last year students from grades 7-12 were invited to design a sculpture. Once all the work was collected, the teachers along with several prominent members of the Springville

Community, judged the work and selected a design created by Sophomore Dakota Ball.

Building it...

The sculpture will use steel beams from the WTC mounted in a fabricated steel circle. The steel has been formally dedicated to S-GI. Dakota's design gracefully symbolizes timelessness, rebirth and continuity. S-GI stu-

dents will fabricate the sculpture. We are making final arrangements to pick up the steel in New York. Our goal is to have the foundation work done this summer, and a dedication ceremony in September, the tenth anniversary of the 9/11 attacks.

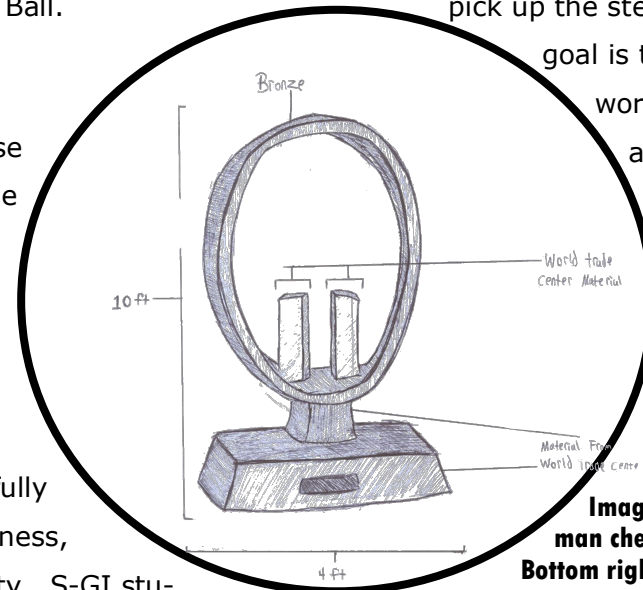

Images: Upper left, Mr. Houseman checks over student designs. Bottom right, Dakota's final design.